



Description

Step shape power family are designed with ultra-slim plastic housing and for full range AC input from 90VAC to 264VAC.

The series are isolation Class II Level, achieving high efficiency and low no-load power consumption. They provide adjustable DC output voltage and operate in wide temperature range.

The good performance can be used for building automation, household and industrial control systems etc.



Features

- AC input with 90-264VAC
- No load power consumption <0.3W
- Isolation Class II
- DC output voltage adjustable
- Pass LPS (Limited power source) for Blank type
- Protections: Short circuit/Over load/Over voltage
- Cooling by free air convection (working temperature: -20~+70 °C)
- Din rail TS-35/7.5 or 15 mountable
- LED indicator for power on
- Three years warranty

Application Scenarios

- Robotics and Automated Equipment
- Industrial Automation Control System
- New Energy Equipment
- Intelligent Building Management System

Product Naming Conventions

DRA	100	-XX
Product Series Name	Output power 100 - 100W	Output Voltage 12 - 12.0V 15 - 15.0V 24 - 24.0V 48 - 48.0V

DRA100-XX: 92.2W max, Pass LPS with a narrower output adjustable range
 DRA100N-XX: 100W max, No-LPS with a wide output adjustable range

Important Notice

Please read this technical specification carefully before installation and usage.
 The product must be installed and debugged by professionals.
 Please ensure that the input power is disconnected during installation.

Technical Parameters

Safety Model No.	DRA100-12	DRA100-15	DRA100-24	DRA100-48
Output				
DC Voltage	12V	15V	24V	48V
Rated Current	7.1A	6.13A	3.83A	1.92A
Rated Power	85.2W	92W	92W	92.2W
Ripple & Noise(max.)	120mVp-p	120mVp-p	150mVp-p	240mVp-p
Voltage Tolerance	±2.0%	±1.0%	±1.0%	±1.0%
Line Regulation	±1.0%	±1.0%	±1.0%	±1.0%
Load Regulation	±1.0%	±1.0%	±1.0%	±1.0%
Voltage ADJ. Range	12.0~13.0V	15.0~17.0V	24.0~25.5V	48.0~48.7V
Capacitive Loads	10000uF Min	6400uF Min	2500uF Min	1100uF Min
Setup, Rise, Hold up Time	0.5s,50ms,30ms/230VAC(at full load)		0.5s,50ms,12ms/115VAC(at full load)	
No-load Power Consumption	0.3W			
Efficiency(100%Load)	88%	88%	90%	91%

	DRA100-12N	DRA100-15N	DRA100-24N	DRA100-48N
Output				
DC Voltage	12V	15V	24V	48V
Rated Current	7.5A	6.5A	4.17A	2.08A
Rated Power	90W	97.5W	100W	100W
Ripple & Noise(max.)	120mVp-p	150mVp-p	240mVp-p	240mVp-p
Voltage Tolerance	±1.0%	±1.0%	±1.0%	±1.0%
Line Regulation	±1.0%	±1.0%	±1.0%	±1.0%
Load Regulation	±1.0%	±1.0%	±1.0%	±1.0%
Voltage ADJ. Range	12~13V	13.5~18.0V	21.6~29.0V	43.2~55.2V
Capacitive Loads	6400uF Min	2500uF Min	1100uF Min	1000uF Min
Setup, Rise, Hold up time	0.5s,50ms,30ms/230VAC(at full load)		0.5s,50ms,12ms/115VAC(at full load)	
No-load Power consumption	0.3W			
Efficiency(100%load)	88%	89%	90%	90%

* Ripple & noise are measured from peak to peak with bandwidth limit of 20MHz 0.1uF and 47uF/50V parallel capacitor under DC output full load, AC nominal input 25°C).

* All parameters NOT specially mentioned at 230VAC input, rated load and 25°C of ambient temperature.

Input	
Rated Voltage Range	100-240VAC
AC Voltage Range	90-264VAC/127~370VDC
Nominal Network Frequency	50/60Hz
AC Current	2.4A/115VAC 1.2A/230VAC
Inrush Current	Cold Start 60A/200us at 230VAC 50Hz Cold Start 30A/200us at 115VAC 50Hz
Leakage Current	2mA max.
Power Factor	>0.5/230VAC at full load >0.5/115VAC at full load

* All parameters NOT specially mentioned at 230VAC input, rated load and 25°C of ambient temperature.

Technical Parameters

Safety Model No.	DRA100-12 DRA100-12N	DRA100-15 DRA100-25N	DRA100-24 DRA100-24N	DRA100-48 DRA100-48N
Protection				
Over Load	105% ~ 160% rated output power			
	Hiccup mode when output voltage <50%, recovers automatically after fault condition is removed.			
	Constant current limiting within 50 ~ 100% rated output voltage, recovers automatically after fault condition is removed.			
Over Voltage	14.2 ~ 16.2V	18.8 ~ 22.5V	18.8 ~ 22.5V	30 ~ 36V
	30 ~ 36V	30 ~ 36V	56.5 ~ 64.8V	56.5 ~ 64.8V
Shut down o/p voltage, re-power on to recover.				
Over Temperature	NA			
Short Circuit	Constant current Limiting within 130 ~ 150% rated output power for more than 5 seconds and			
	then shut down o/p voltage, re-power on to recover.			
Internal Fuse At L Pin	F5 A /250V			

* All parameters NOT specially mentioned at 230VAC input, rated load and 25°C of ambient temperature.

Environmental Conditions	
Working TEMP.	-20~+70°C (Please refer to“Derating Curve”section)
Working Humidity	20~95%RH Non-condensing
Storage TEMPHumidity	-40~+85°C ,10~95%RH Non-condensing
TEMP. Coefficient	0.03%/°C (0~50°C) RH Non-condensing
Vibration	10~500Hz,2G 10min./1cycle, 60min. each along X, Y, Z axes;
Start-up tested temp.	-20°C (full load max.)
Operating Altitude	2000 meters
Over Voltage Category	II, According to EN62368-1; altitude up to 2000 meters
Pollution Degree	2

* All parameters NOT specially mentioned at 230VAC input, rated load and 25°C of ambient temperature

* Derating may be needed under low input voltage .Please check the derating curve for more details.

* The ambient temperature derating of 3.5 /1000m for operating altitude higher than 2000m(6500ft).

Mechanical	
Packing	250g/pcs; 40 x 22 x 35 cm; 50pcs/carton
Dimension (HxWxD)	90.02 x 70.2 x 58.4 mm
MTBF	841.6Khrs min. MIL-HDBK-217F(25)
Housing material	Plastic

* Installation clearances : top with 40mm, bottom with 20mm,left and right with 5mm.Increase the space to10-15mm when the adjacent device is heat source.

Safety & Electromagnetic compatibility	
Safety Standards	Comply with UL62368-1,BS EN/EN62368-1
Withstand Voltage	I/P-O/P:3KVAC
Isolation Resistance	I/P-O/P:>100M Ohms/500VDC/25 /70% RH
EMC Emission	Compliance to BS EN/EN55032,BS EN/EN61000-3-2,-3
EMC Immunity	Compliance to BS EN/EN61000-4-2,3,4,5,6,8,11, BS EN/EN55035, BS EN/EN61000-6-2, BS EN/EN61204-3

Mechanical Dimensions and Installation

Dimension drawing
(Unit: mm , tolerance: ±1mm)

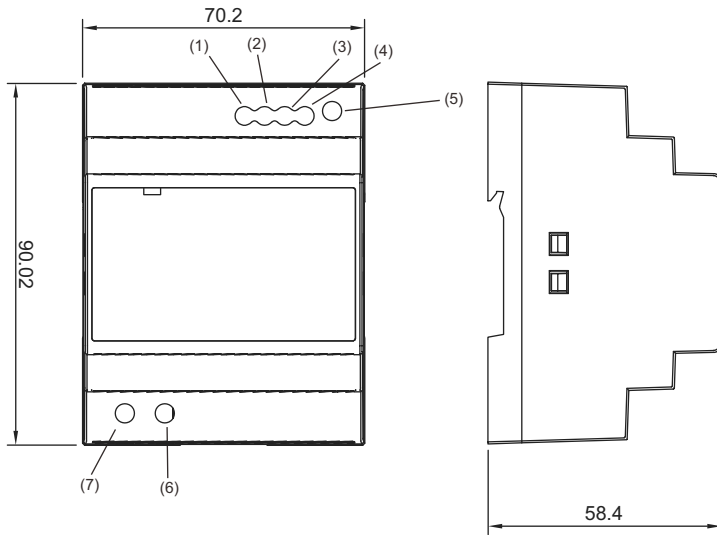

No.	Assignment
1	DC Output(V-)
2	DC Output(V-)
3	DC Output(V+)
4	DC Output(V+)
5	Voltage adjustment
6	AC/N
7	AC/L

No.	Stripping length	Tightening torque
1,2,3,4	5-7mm	0.4Nm
6,7	5-7mm	0.5Nm

Dimensions	Installation method	Terminal
Depth: 58.4 mm Width: 70.2 mm Height: 90.02 mm	40mm DIN Installation Vertical installation 20mm Heat Dissipation Space	Input terminal: Screw Terminal Output terminal: Screw Terminal Wiring Specifications:12-24AWG

* Installation clearances : top with 40mm, bottom with 20mm, left and right with 5mm. Increase the space to 10-15mm when the adjacent device is heat source.

Installation

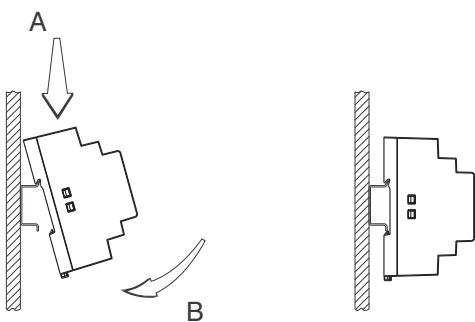

Connect the power supply card to the DIN rail

Please follow the steps below to install the power supply:

1. Mount the power supply to the DIN rail from above in the normal mounting position. The universal DIN rail adapter is in the correct position behind the DIN rail (A)
2. Then press down on the power supply until you hear the universal DIN rail adapter makes a locking sound into position (B).
3. Check if the power supply is firmly mounted on the DIN rail.



- (1) The power unit has to be installed and put into operation by qualified personnel only, under consideration of the latest country-specific standards and regulations.
- (2) Install the device in an enclosure providing protection against electrical, mechanical and fire hazards.
- (3) The power unit is designed for vertical mounting with input terminals on the bottom of the device. The mounting rail is standard TS 35/7.5 or TS 35/15 according to DIN EN 60715

Block Diagram

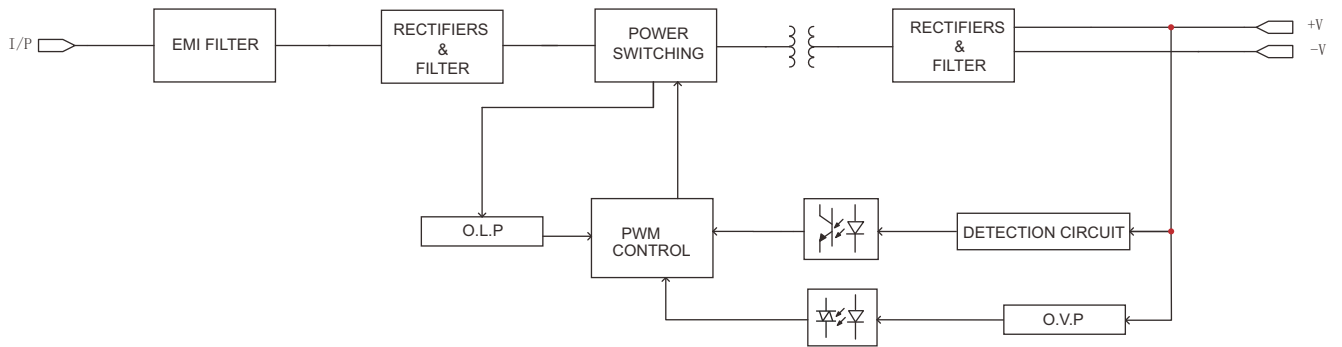

Engineering Data

Derating Curve

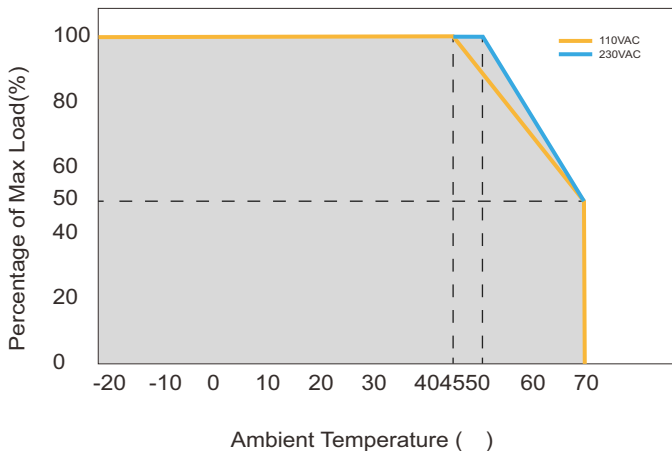

Fig. 1.

Static Characteristics

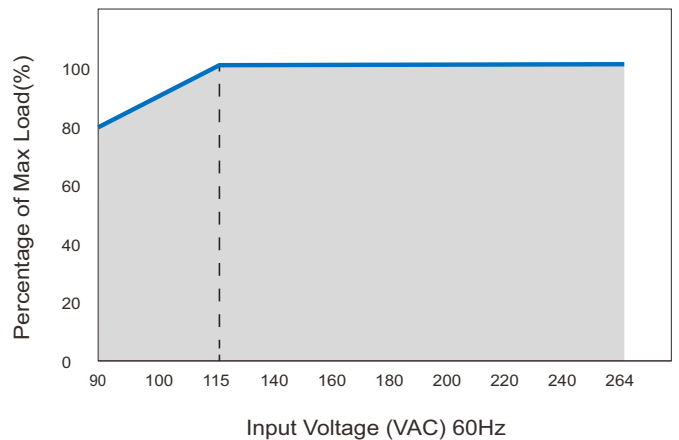

Fig. 2.

1. Power supply components may degrade, or be damaged, when the power supply is continuously used outside the shaded region, refer to the graph shown in Fig. 1.
2. The PSU will be bouncing and start up time will not exceed 5s when ambient temperature at 30°C.
3. If the output capacity is not reduced when the surrounding air temperature > 45°C, the device will run into Over Temperature Protection. When activated, power supply will latch off, until the surrounding air temperature is lowered or the load is reduced as far as necessary to keep the device in working condition, and require removal/re-application of input AC voltage in order to restart.
4. In order for the device to function in the manner intended, it is also necessary to keep a safety distance as recommended in the safety instructions while the device is in operation.
5. Depending on the surrounding air temperature and output load delivered by the power supply, the device can be very hot!
6. Need to consider power de-rating if surrounding Air Temperature large than 45°C at 230 Vac.
7. If the device has to be mounted in any other orientation, please leave a message via the Contact Us form.